



# AD4-AD6 I/O Modules Analog-to-Digital Function Modules

## 16 A/D Channels; 16-bit SAR, 8 Chx2 A/D multiplexed

Modules AD4-AD6 feature 16 channels with up to 16-bit SAR A/D converters for one per 8 channel multiplexed bank/2 banks. The maximum programmable expected full scale range input for each module is:

- AD4:  $\pm 10.00$ ,  $\pm 5.00$ ,  $\pm 2.50$  or  $1.25$  volts respectively, where range is -FS to +FS, 0 to FS, or  $\pm 25$  mA
- AD5: 50.00, 25.00, 12.50 or 6.25 volts respectively, where range is -FS to +FS or 0 to FS
- AD6: 100.00, 50.00, 25.00 or 12.50 volts respectively, where range is -FS to +FS or 0 to FS

The A/D converters have programmable sample rates of up to 400 kHz/aggregate per bank of 8 channels.

The input range and gain is also field-programmable for each channel. The ability to set lower expected, full-scale voltage gain ranges assures the use of the full resolution. Each channel includes a fixed, second order, anti-aliasing filter and a digital post filter with a programmable breakpoint that enables users to field-adjust the filtering for each channel.

The extended A/D FIFO buffering capabilities of these modules supports greater storage/management of the incoming signal samples (data) for post-processing applications. Data samples can be stored in the buffer either at the maximum programmed base A/D sample rate or by an integer-divided sample rate. Programmable FIFO buffer thresholds maximize data flow control (movement in and out of the FIFO). Incremental relative time-stamping between samples also is provided as a programmable option.

All A/D channels are self-aligning and continuous Background Built-in-Test (BIT) status is provided for channel health and operation feedback. On a rotating basis, each channel is automatically trimmed/tested for optimal conversion and reliability to eliminate offset and gain errors throughout the entire operating envelope (temperature and drift control). Open inputs are sensed and flagged.

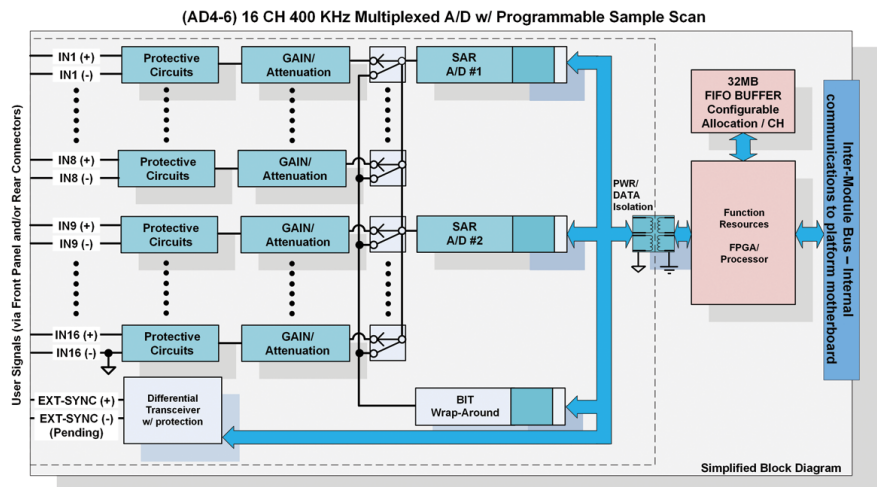
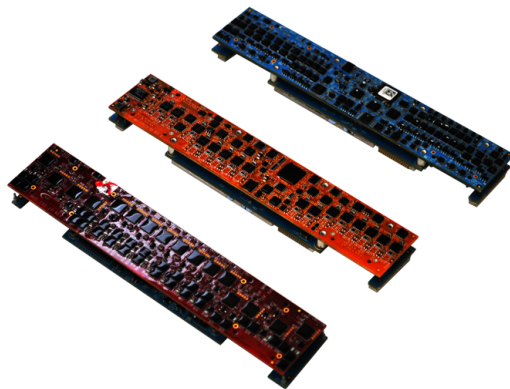

### Features

- Number of Channels: 16
- ADC Type / Architecture: SAR / Individual
- Key Characteristics Range (max):  $\pm 10$  V /  $\pm 25$  mA (AD4);  $\pm 50$  V (AD5);  $\pm 100$  V (AD6)
- Effective Resolution Bits: 16
- Sampling Rate (max.): 400 kHz / Aggregate per bank of 8 Channels

## Specifications

Resolution	16-bit SAR A/D converters. One per 8 channel multiplexed bank/2 banks.
Input Format	AD4: Differential voltage (may be used as single-ended by grounding one input). Single direction DC current. AD5-AD6: Differential voltage (may be used as single-ended by grounding one input).
Input Scaling	Sixteen (16) bipolar or unipolar channels (volts) or (current). Programmable, per channel, as Full Scale (FS) range inputs where range is -FS to +FS or 0 to FS; ADE: 10.00, 5.00, 2.50, 1.25 or 0.625 volts; ADF: 100.0, 50.0, 25.0, 12.5 or 6.25 volts; ADG: 25, 12.5 mA. The ability to set lower voltages for FS assures the utilization of the full resolution.
Overvoltage Protection	AD4: No damage up to $\pm 20$ V continuous, $\pm 30$ V momentary; AD5: No damage up to $\pm 60$ V continuous, $\pm 80$ V momentary; AD6: No damage up to $\pm 120$ V continuous, $\pm 150$ V momentary
Overcurrent Protection	30 mA when set for current mode (AD4 only).
Open Input Sense	This module will sense and report unconnected inputs (AD4 only)
Input Impedance	AD4: 10 M $\Omega$ min. / 49.9 $\Omega$ current mode; 20 M $\Omega$ (Differential); AD5: 276 k $\Omega$ (Differential); AD6: 526 k $\Omega$ (Differential)
Linearity/Accuracy	AD4: $\pm 1.25$ V or 0 to 1.25 V Range: $\pm 0.1\%$ + ( $\pm 25$ mV); All Other Ranges: $\pm 0.1\%$ FS range over temperature (voltage/current); AD5: $\pm 0.1\%$ FS range over temperature (voltage/current); AD6 : $\pm 0.15\%$ FS range over temperature (voltage/current); no missing codes to 16-bits.
Gain Error	AD4: $\pm 0.1\%$ FS range (voltage mode); $\pm 0.25\%$ FS range (current mode); AD5: $\pm 0.1\%$ FS range (voltage/current); AD6: $\pm 0.15\%$ FS range (voltage/current)
Offset Error	AD4: $\pm 0.04\%$ FS range or $\pm 5$ mV, the greater of (voltage mode); $\pm 0.02\%$ FS range (current mode); AD5-AD6: $\pm 0.02\%$ FS range
Integral Non-Linearity (INL)	$\pm 3$ LSB's max.
Differential Non-Linearity (DNL)	AD4: $\pm 1$ LSB's max. (monotonic); AD5-AD6: $\pm 3$ LSB's max. (monotonic)
Sampling Rate	400 KSPS maximum aggregate, per bank of 8 channels, programmable.
Data Buffering/Triggering	Programmable channel sampling scan (programmable for all (16) channels). Each channel per bank can be programmed for selective scanning sequence. See Operations Manual for details.
Acquisition & Conversion Time	3 $\mu$ s at 400 kHz sampling rate (max). See manual for conversion time at lower sample rates.
Throughput	3 $\mu$ s max. (between samples - time for data sample to propagate to data register) / with filter – single channel scan.
Programmable Filter	Each channel incorporates a fixed second order anti-aliasing filter and a post filter that has a digitally adjustable break point (programmable from 10 Hz to 200 kHz in 10 Hz steps).
Common Mode Rejection	90 dB min. at 60 Hz. Roll off to 50 dB min. at 10 kHz.
Common Mode Voltage	AD4: Signal voltage plus Common mode voltage is 10.5 volts; AD5: Signal voltage plus Common mode voltage between channels is 50 volts; AD6: Signal voltage plus Common mode voltage between channels is 100 volts. NOTE: A/D differential inputs must not “float”. Input source must have return path to ground.
Output Logic	Bipolar output in two's complement. Bipolar output range from FFFF 8000 max. negative; 0000 7FFF is max. positive (FS); Unipolar output range from 0000 0000 to 0000 FFFF (FS) (Voltage Ranges only).
ESD Protection	Designed to meet the testing requirements of IEC 801-2 Level 2. (4 KV transient with a peak current of 7.5 A and TRcR of approximately 60 ns).
Power	5 VDC @ 100 mA/150 mA max (typ. / max.); $\pm 12$ VDC @ 220 mA/330 mA (typ. / max.)
Ground	Channel inputs are differential, referenced to isolated module AGND, isolated (250 V minimum peak isolation) from system power/ground.
Weight	1.5 oz. (42 g)

## Architected for Versatility

NAI's Configurable Open Systems Architecture™ (COSA®) offers a choice of over 100 smart I/O, communications, or Ethernet switch functions, providing the highest packaging density and greatest flexibility of ruggedized embedded product solutions in the industry. Preexisting, fully-tested functions can be combined in an unlimited number of ways quickly and easily.

## One-Source Efficiencies

Eliminate man-months of integration with a configured, field-proven system from NAI. Specification to deployment is a seamless experience as all design, state-of-the-art manufacturing, assembly and test are performed - by one trusted source. All facilities are located within the U.S. and optimized for high-mix/low volume production runs and extended lifecycle support.

## Product Lifecycle Management

From design to production and beyond, NAI's product lifecycle management strategy ensures the long-term availability of COTS products through configuration management, technology refresh and obsolescence component purchase and storage.

All specifications are subject to change without notice. All product and company names are trademarks or registered trademarks of their respective holders



Made in the USA  
Certified Small Business